



CISSE INTERMEDIATE LEVEL

NETWORKING AND DATA COMMUNICATION

WEDNESDAY: 4 December 2024. Afternoon Paper.

Time Allowed: 3 hours.

Answer ALL questions. This paper has two sections. SECTION I has twenty (20) short response questions carrying forty (40) marks. SECTION II has three (3) practical questions carrying sixty (60) marks. Marks allocated to each question are indicated in the question.

Required Resources:

- **A computer**
- **Simulator (Packet tracer/GNS 3)**
- **Wireshark**

SECTION I (40 MARKS)

1. Give the binary number 10011101 convert it to its decimal equivalent. (2 marks)
2. You are the network administrator at ABC company. ABC company has been assigned the class C IP address 189.66.1.0 by its Internet Service Provider. If you divide the network range by using the 255.255.255.224 subnet mask, how many hosts can be supported on each network? (2 marks)
3. In a busy office, employees use high-bandwidth applications like file transfers, video conferencing, and cloud services. To reduce congestion and enhance performance, the IT department upgrades the network infrastructure with a network adapter capable of managing multiple data streams at once. Which term describes this adapter's ability to handle multiple data streams simultaneously? (2 marks)
4. Network optimisation involves adjusting network parameters and configurations to ensure peak performance. Which feature of a network adapter enables automatic detection and adjustment of network speed and duplex settings to enhance performance? (2 marks)
5. Which technique is used in communication systems to prevent electromagnetic interference and crosstalk while preserving data integrity by encasing the signal-carrying component in protective layers? (2 marks)
6. Employees use a video conferencing application to collaborate on a project, requiring a stable connection throughout the call. This involves setting up the channel, managing data flow and closing the connection when the session ends. Which OSI model layer is responsible for creating, maintaining and terminating connections between applications? (2 marks)
7. The TCP/IP reference model is a conceptual framework that outlines communication process within a network. Which layer is responsible for routing packets across multiple networks and ensuring they reach their destination? (2 marks)
8. Which term describes a spanning-tree network that has all switch ports in either the blocking or forwarding state? (2 marks)
9. Which parameter would you tune to affect the selection of a static route as a backup, when a dynamic protocol is also being used? (2 marks)

10. Refer to the exhibit given below which user-mode password has just been set? (2 marks)

```
Router#config1
Router(config)#line vty 04
Router(config-line)#password c1 sc0
Router(config-line)#login
```

11. Which term refers to a group of interconnected networks under shared administrative control, typically managed by a single organisation? (2 marks)
12. What is the default administrative distance of OSPF (open shortest path first)? (2 marks)
13. A corporation needs to transfer sensitive financial reports between two remote offices. To ensure the security of the data during transmission, the Informational Technology (IT) team decides to use a protocol that encrypts both the files and the commands used to send them, protecting any intercepted data from unauthorised access. Which protocol is commonly used for secure file transfers, encrypting both data and command channels during transmission? (2 marks)
14. Which term describes the technique of dividing a single physical network into multiple logical networks, allowing different broadcast domains to coexist within the same switch? (2 marks)
15. If a router has four interfaces and each interface is connected to four switches, how many broadcast domains are present on the router? (2 marks)
16. If attackers intercept and crack weak encryption keys, a company's wireless network can be compromised. Which type of attack targets this vulnerability by trying to decode the encryption key used to secure wireless communications? (2 marks)
17. Employees in a corporate office are experiencing frequent connectivity issues due to disruptions on the network's frequency band. Which network tool can the administrator use to identify the source of interference and address the problem? (2 marks)
18. Which type of documentation visually represents both the physical and logical topology of a network, including devices, connections and IP addressing schemes? (2 marks)
19. A small branch office is experiencing intermittent connection problems with its main office. Employees report slow access to shared files and frequent network disconnections. Which network troubleshooting technique involves sending a continuous stream of data packets to a specific device to measure response time and packet loss, assisting in diagnosing connectivity issues? (2 marks)
20. What is the default VLAN on an access port? (2 marks)

SECTION II (60 MARKS)

Required Resources:

- GNS3 or Packet tracer
- Internet connection
- Windows or Linux PC

21. Create a word processor document named “Question 21” and use the document to save solution to questions (a) to (d) below.

A mid-sized enterprise organisation is setting up its network and different departments have varying requirements for subnet sizes. The network administrator must efficiently allocate IP addresses by utilising Variable Length Subnet Masking (VLSM).

The network topology should be designed using an appropriate simulator, adhering to the following criteria:

- **IP Address Assignment:**
 - Use the network address 192.168.0.0/24 as the base address.
 - Allocate subnets using VLSM according to the following department requirements:
 - ✓ **Operations:** 50 hosts
 - ✓ **Administration:** 25 hosts
 - ✓ **Marketing:** 10 hosts
 - ✓ **Sales:** 5 hosts
 - ✓ **IT Support:** 2 hosts
 - Assign the smallest possible subnet to each department to minimise IP address wastage.
- **Network Topology Setup:**
 - Each department is connected to a dedicated router interface and the routers are linked together through a shared backbone connection.

Required:

- (a) Calculate the suitable subnet masks for each department using Variable Length Subnet Masking (VLSM). (6 marks)
- (b) Design the network topology according to the provided criteria. (6 marks)
- (c) Assign the first usable IP address of each subnet to the router interface connected to its corresponding department. Display the configuration details for one of the intermediary devices. (4 marks)
- (d) Test connectivity between end devices that belong to Operations department. (4 marks)

Save “Question 21” document and upload.

(Total: 20 marks)

22. Create a word processor document named “Question 22” and use the document to save solution to questions (a) to (e) below.

Using GNS3 or Packet Tracer Configure the topology as shown below:

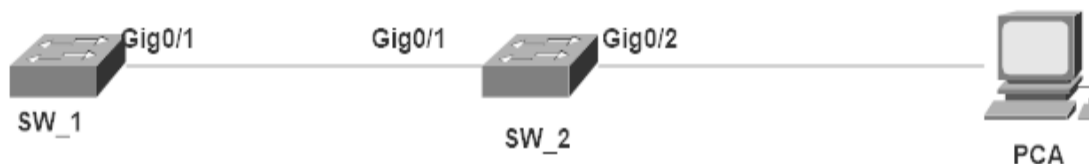

Required:

- (a) Configure the IP addresses according to the above topology then establish remote access to SW_2 from SW_1. (6 marks)
- (b) From SW_2, test the connectivity to PCA by using an extended Ping command with a repeat count of 100. (4 marks)

- (c) On SW_1 configure warning banner. (3 marks)
- (d) Configure SW_2 to prevent console messages from interrupting command entry. (3 marks)
- (e) Configure the interface connecting the switches to operate as trunk ports. (4 marks)

Save “Question 22” document and upload.

(Total: 20 marks)

23. Create a word processor document named “Question 23” and use the document to save solution to questions (a) to (j) below.

Configure the topology below and answer the questions that follow:

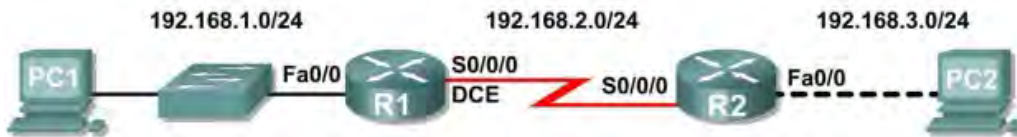

Addressing Table

Device	Interface	IP Address	Subnet Mask	Default Gateway
R1	Fa0/0	192.168.1.1	255.255.255.0	N/A
	S0/0/0	192.168.2.1	255.255.255.0	N/A
R2	Fa0/0	192.168.3.1	255.255.255.0	N/A
	S0/0/0	192.168.2.2	255.255.255.0	N/A
PC1	N/A	192.168.1.10	255.255.255.0	192.168.1.1
PC2	N/A	192.168.3.10	255.255.255.0	192.168.3.1

Required:

- (a) Configure the router name as R1. (2 marks)
- (b) Configure the Serial0/0/0 interface with the IP address 192.168.2.1/24. Set the clock rate to 64000. (2 marks)
- (c) Configure the FastEthernet 0/0 interface with the IP address 192.168.3.1/24. (2 marks)
- (d) Configure the console password on the router. The password should be the word “exam”. (2 marks)
- (e) Configure the Fast Ethernet 0/0 interface with the IP address 192.168.1.1/24. (2 marks)
- (f) Configure the IP addresses on the PCs. (2 marks)
- (g) Configure the Serial 0/0/0 interface with the IP address 192.168.2.2/24. (2 marks)
- (h) Save the R1 and R2 configurations. (2 marks)
- (i) Test connectivity between the R1 router and PC1 and from PC1 to R1. (2 marks)
- (j) Examine the configurations on the fast-Ethernet-0/0. (2 marks)

Save “Question 23” document and upload.

(Total: 20 marks)

.....



CISSE INTERMEDIATE LEVEL

NETWORKING AND DATA COMMUNICATION

WEDNESDAY: 21 August 2024. Afternoon Paper.

Time Allowed: 3 hours.

Answer ALL questions. This paper has two sections. SECTION I has twenty (20) short response questions carrying forty (40) marks. SECTION II has three (3) practical questions carrying sixty (60) marks. Marks allocated to each question are indicated in the question.

Required Resources:

- **A computer**
- **Simulator (Packet tracer/GNS 3)**
- **Wireshark**

SECTION I (40 MARKS)

1. Which network type does **NOT** use centralised authentication and instead allows each machine to be self-managed? (2 marks)
2. Domain refers to a collection of computers, devices and resources that are managed under a common set of rules and policies. Which aspect of domains supports large-scale networks, making them ideal for enterprises with a big number of users and devices spread over various physical locations, allowing for centralised network administration? (2 marks)
3. A network segment enhances network performance and security. Which network device connects multiple network segments together at the data link layer (Layer 2) of the OSI model? (2 marks)
4. VLANs are used to logically partition a network into smaller broadcast domains, resulting in improved network management, security and performance. Which method is used to route network traffic between distinct virtual LANs (VLANs) on a network? (2 marks)
5. Which layer of the OSI model is largely responsible for MAC addresses and layer 2 switching? (2 marks)
6. Which internet protocol suite does **NOT** create a connection prior to data transmission and does not guarantee delivery or order of delivery? (2 marks)
7. PC-A has an IPv4 address of 172.16.10.70 with a subnet mask of 255.255.255.224. What is the network address for PC-A? (2 marks)
8. Which flag is used with the netstat command to display numerical addresses rather than resolve them to host names? (2 marks)
9. Routing protocols ensure data packets are efficiently and reliably delivered to their intended destinations. Which routing protocol uses the distance vector algorithm? (2 marks)
10. Which DNS resource record types identifies authoritative name servers? (2 marks)
11. Network Time Protocol (NTP) is commonly used to synchronise time across a variety of systems, such as servers, workstations, routers and other network infrastructure devices. Which port does NTP use for communication? (2 marks)
12. The process-to-process protocol that adds only port addresses, checksum error control and length information to the data from the upper layer is referred to as _____ . (2 marks)

13. Which is the mode of transmission shown by the figure below is _____ . (2 marks)

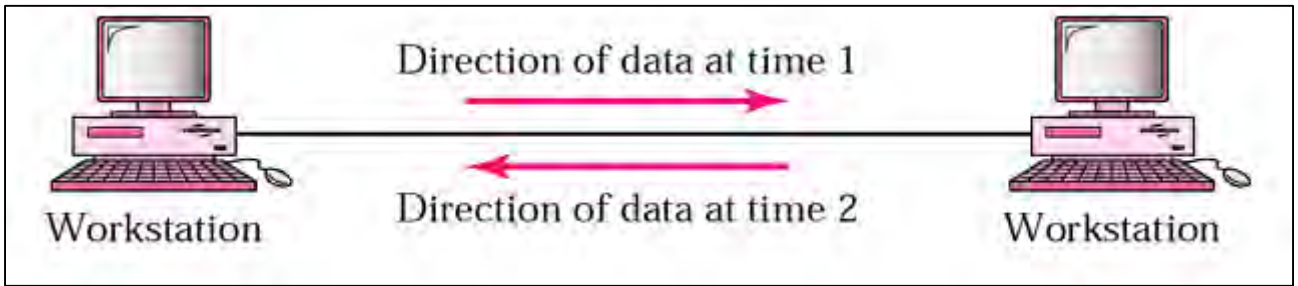

14. Which type of transmission is the bit stream combined into longer “frames” that may contain multiple bytes that are transmitted as an un-broken string of 1’s and 0’s and the receiver separates that string into bytes or characters? (2 marks)
15. The measure of the quality of a system that indicates the strength of the signal with respect to the noise power in the system and is usually given in dB (“decibel”) is called _____. (2 marks)
16. The encoding technique that uses only one level of value where all signal levels are on one side of the time axis either above or below like in the figure below is referred to as _____. (2 marks)

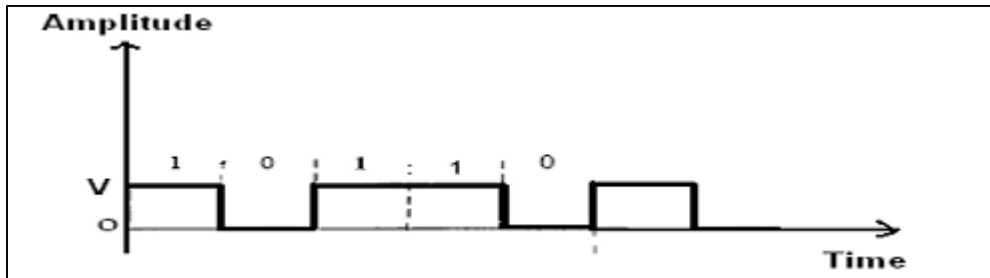

17. A switch is a networking device that connects multiple devices such as computers, printers and servers on the same network within a building or campus. Which switch characteristic helps to alleviate network congestion when a 100 Mbps port is forwarding data to a 1 Gbps port? (2 marks)
18. What is the maximum number of IP addresses that can be assigned to hosts on a local subnet that uses the 255.255.255.224 subnet mask? (2 marks)
19. The port on a network switch that allows data to flow across a network node for multiple virtual Local Area Networks or VLANs is called _____. (2 marks)
20. A verification process by which a computer can gain access to a wireless network that uses the Wired Equivalent Privacy (WEP) protocol is called _____. (2 marks)

SECTION II (60 MARKS)

21. Create a word processor document named “Question 21” and use the document to save solutions to questions (a) to (f) below.

Using GNS3 or packet tracer, configure the topology as shown below:

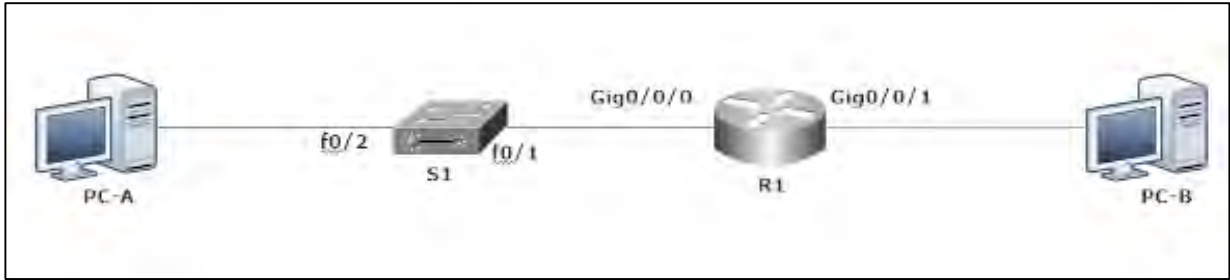

Device	Interface	IP Address/Prefix	Default Gateway
R1	G0/0/0	192.168.20.1/24	N/A
		2001:DAAD:0DB8:20: :1/64	
		FE80::1	
	G0/0/1	192.168.30.1/24	
		2001:DAAD:0DB8:30: :/64	
		FE80::1	
S1	VLAN	192.168.20.2/24	192.168.20.1
		2001:DAAD:0DB8:20: :2/64	FE80::1
PC-A	NIC	192.168.20.3/24	192.168.20.1
		2001:DAAD:0DB8:20: :3/64	FE80::1
PC-B	NIC	192.168.30.2/24	192.168.30.1
		2001:DAAD:0DB8:30: :2/64	FE80::1

www.chopi.co.ke

Required:

- (a) Configure IPv4 address as displayed in the topology and test connectivity between PC-A and PC-B. (4 marks)
- (b) Configure the Switch's default gateway based on the network it is based in. (2 marks)
- (c) Set up local authentication on the switch, using telnet for remote login and access it using PC-B. (4 marks)
- (d) From the Router, set #style2024 as the privileged EXEC encrypted password. (2 marks)
- (e) Create a banner that warns anyone accessing the device that unauthorised access is prohibited. (4 marks)
- (f) From the Router use appropriate command to discover neighboring intermediary devices that are directly linked to it? (4 marks)

Save “Question 21” document and upload.

(Total: 20 marks)

22. Create a word processor document named “Question 22” and use the document to save solution to questions (a) to (e) below.

Using appropriate network utility, use your computer to perform the following:

- (a) Using appropriate command utility, check the connectivity between your computer and a public Domain Name System (DNS) server operated by Google. (4 marks)
- (b) Trace the path to www.gmail.com using the appropriate command utility without first converting IP addresses to hostnames. (4 marks)
- (c) Using the appropriate command utility, show Fully Qualified Domain Names (FQDN) for foreign addresses. (4 marks)
- (d) Using appropriate command utility, display IPv6 routing table. (4 marks)
- (e) Use the appropriate command to acquire the domain name or IP address mapping of www.amazon.com. (4 marks)

Save “Question 22” document and upload. (Total: 20 marks)

23. Using a network simulator such as Wireshark, answer the following questions.

Using a word processor document create a file called “Question 23” and capture screenshots of your findings.

- (a) ABZ Company has been given the IP Address of 199.2.1.0 /24 to the subnet. The company plans to put each of the 5 floors in their building on its own subnet. What is the IP range of the LAST available network once they subnet? (Show your working). (5 marks)
- (b) ABC your ISP has given you the address 223.5.14.6/29 to assign to your router’s interface. They have also given you the default gateway address of 223.5.14.7. After you have configured the address, the router is unable to ping any remote devices. What is preventing the router from pinging remote devices? (Support your answer). (5 marks)
- (c) An enterprise uses a firewall as the egress device. Employees in the interface need to access the internet through the firewall, and one server in the enterprise network provides services for internet users. After NAT is configured on the egress firewall, multiple users on the intranet can access the internet using a small number of public IP addresses, and extranet users can access the Intranet server using specified IP addresses.

Using a network simulator such as Wireshark, draw the network topology using the information provided above and the details on the table below, configure the basic IP addresses, security zones and security policies. (10 marks)

Device	Interface	IP Address
FW1	GigabitEthernet0/0/1	10.1.2.1/24
	GigabitEthernet0/0/2	40.1.1.1/24
	GigabitEthernet0/0/3	10.1.1.1/24
PC1	Eth0/0/1	10.1.2.100/24
PC2	Eth0/0/1	40.1.1.100/24
Server 1	Eth0/0/1	10.1.1.100/24

Save “Question 23” document and upload. (Total: 20 marks)

.....



CISSE INTERMEDIATE LEVEL

NETWORKING AND DATA COMMUNICATION

WEDNESDAY: 24 April 2024. Afternoon Paper.

Time Allowed: 3 hours.

Answer ALL questions. This paper has two sections. SECTION I has twenty (20) short response questions carrying forty (40) marks. SECTION II has three (3) practical questions carrying sixty (60) marks. Marks allocated to each question are indicated in the question.

Required Resources:

- **A computer**
- **Simulator (Packet tracer/GNS 3)**
- **Wireshark**

SECTION I (40 MARKS)

1. In which data transmission mode does communication occur in both directions, but not simultaneously? (2 marks)
2. Which network device connects multiple networks and makes decisions about the most efficient path for data to travel between them? (2 marks)
3. Which network media is used to transmit data encoded as light pulses? (2 marks)
4. What is the term used to refer to all network-connected computers that actively engage in network communication? (2 marks)
5. Which network infrastructure provides a controlled and secure network extension outside the boundaries of an organisation that enables authorised individuals to access specific resources, collaborate on projects or share information? (2 marks)
6. Which network device uses MAC addresses to determine forwarding decisions and operates at the OSI model's Layer 2 (Data Link Layer)? (2 marks)
7. Which type of policy allows a router to control the flow of voice and data traffic, prioritising voice calls when network congestion arises? (2 marks)
8. What is the name given to a device that makes it possible for devices to connect to a wireless network and access the Internet? (2 marks)
9. Redundancy is the ability to reach a target through multiple paths. What is the general term for this type of network architecture? (2 marks)
10. How is a switch's privileged EXEC mode access secured, assuming "XyZ" is the password? (2 marks)
11. In the OSI model, which layer is in charge of encryption and compression? (2 marks)
12. Which subnet does the IP address 172.16.100.50 belong, if a subnet mask of 255.255.0.0 is used? (2 marks)
13. Which protocol function at the internet layer is used for sending error messages and operational information about network conditions? (2 marks)
14. Which information must be examined in order for the packet to be forwarded to a remote destination, when received by the router? (2 marks)

15. If a subnet has a mask of /29, how many IP addresses are available for hosts? (2 marks)
16. What does the IP address 192.168.10.64/27 represent? (2 marks)
17. A network topology that provides direct optical links between two specific endpoints is referred to as _____. (2 marks)
18. Which type of IPv6 address is exclusively used for communication within a single subnet and cannot be routed? (2 marks)
19. At which layer does the actual transmission of bits over the physical medium occur in the OSI model? (2 marks)
20. What is the name of the transmission medium shown below? (2 marks)



SECTION II (60 MARKS)

Instruction:

Use appropriate network simulator to answer the questions below.

21. Using a word processor create a document called “Question 21” and use it to capture a screenshot of your findings.

Consider a network configuration shown below and use it to answer questions below.

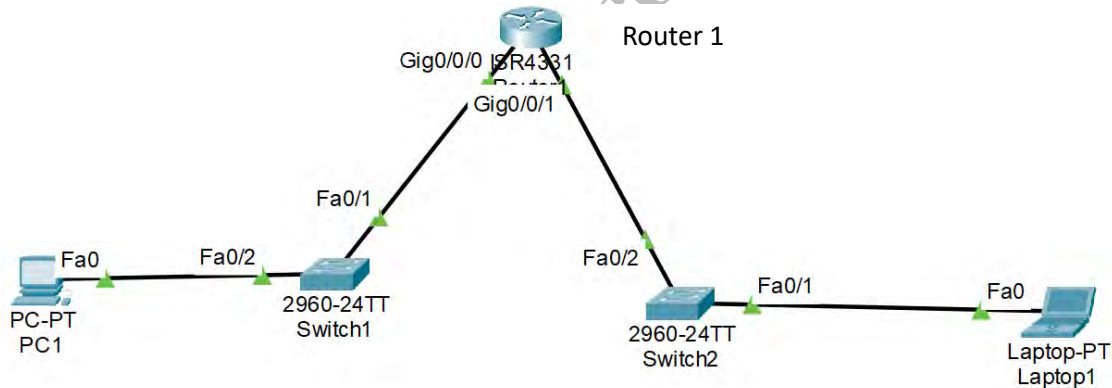

Device	Interface	IP Address	Subnet Mask	Default Gateway
Router 1	Gig0/0/0	192.168.2.1	255.255.255.0	N/A
Router 1	Gig0/0/1	10.10.10.1	255.0.0.0	N/A
Switch1	VLAN1	192.168.2.2	255.255.255.0	192.168.2.1
Switch2	VLAN1	10.10.10.2	255.0.0.0	10.10.10.1
PC1	NIC	192.168.2.3	255.255.255.0	192.168.2.1
Laptop1	NIC	10.10.10.3	255.0.0.0	10.10.10.1

- (a) Configure the topology by adding the network components shown giving them appropriate IP addresses as shown in the addressing table. (10 marks)
- (b) Configure router1 to be securely accessed remotely. (4 marks)
- (c) From PC1 securely access router1 remotely. (2 marks)
- (d) Use the appropriate command to trace the path between PC and laptop. (2 marks)
- (e) Using the appropriate command display the routing table. (2 marks)

Save “Question 21” document and upload.

(Total: 20 marks)

22. Using a word processor, create a document called “Question 22” and use it to capture a screenshot of your findings. Configure the topology below and answer the following questions.

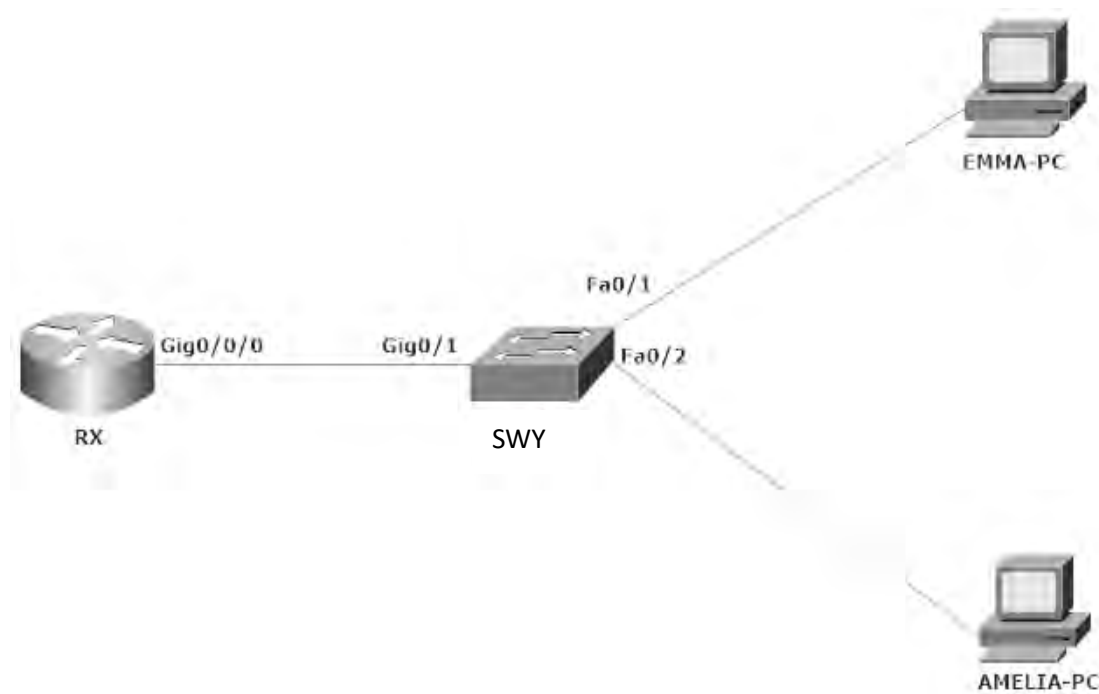

Device	Interface	IP Address	Subnet Mask	Default Gateway
RX	Gig0/0/0	2001:DB8: CAFÉ:100::1	/64	N/A
SWY	VLAN 1	2001:DB8: CAFÉ:100::2	/64	2001:DB8: CAFÉ:100::1
Emma	NIC	2001:DB8: CAFÉ:100::3	/64	2001:DB8: CAFÉ:100::1
Amelia	NIC	2001:DB8: CAFÉ:100::4	/64	2001:DB8: CAFÉ:100::1

- (a) Configure IPv6 address on Intermediary and End devices as follows:
 - (i) RX (2 marks)
 - (ii) SWY (4 marks)
 - (iii) Emma-PC (2 marks)
 - (iv) Amelia-PC (2 marks)

(b) Set up the device on RX so that it may be safely accessed remotely. (6 marks)

(c) Using Emma's PC access the router remotely and display Nonvolatile Random-access Memory settings. (4 marks)

Save "Question 22" document and upload.

(Total: 20 marks)

23. Using a word processor, create a document called "Question 23" and use it to capture a screenshot of your findings.

(a) Using network utility commands, connect to your computer and perform the following:

(i) Display mapping of IP addresses to MAC addresses and capture this screenshot. (3 marks)

(ii) Display your localhost IP routing table and capture this screen shot. (3 marks)

(iii) Display all active network connections and listening ports and capture this screen shot. (3 marks)

(iv) Flush and reset the contents of the DNS client resolver cache. (3 marks)

(v) Display the localhost name. (3 marks)

(vi) Highlight five benefits of troubleshooting a network. (5 marks)

Save "Question 23" document and upload.

(Total: 20 marks)

.....

Chopi.co.ke



CISSE INTERMEDIATE LEVEL
NETWORKING AND DATA COMMUNICATION

WEDNESDAY: 6 December 2023. Afternoon Paper.

Time Allowed: 3 hours.

Answer ALL questions. This paper has two sections. SECTION I has twenty (20) short response questions carrying forty (40) marks. SECTION II has three (3) practical questions carrying sixty (60) marks. Marks allocated to each question are indicated in the question.

Required Resources:

- **A computer**
- **Simulator (Packet tracer/GNS 3)**
- **Wireshark**

SECTION I (40 MARKS)

1. A type of computer network that allows devices to connect to the internet and communicate with each other wirelessly within a limited geographic area, typically within a building, campus, or localised area is known as: (2 marks)
2. What do you call packets that are addressed to all devices in a certain network segment or domain? (2 marks)
3. Your service provider has assigned your organisation the IPv6 prefix 2001:db8:acad::/48. How many bits are available for your business to establish /64 subnetworks with this prefix if interface ID bits are not borrowed? (2 marks)
4. According to the OSI reference model, which switch decides the interface used to forward frames based on the destination MAC address? (2 marks)
5. Given the IP address 192.168.10.0/24, what is the CIDR Notation value if the network is to be divided into 30 hosts? (2 marks)
6. What is the notation for the prefix length for the subnet mask 255.255.255.252? (2 marks)
7. The technology used to logically divide a network into smaller, isolated broadcast domains, even though the devices are physically connected to the same network switch, is known as: (2 marks)
8. Which intermediary device is used to connect different network segments while functioning as a boundary to prevent broadcast traffic from crossing over? (2 marks)
9. What is the term given to the number of network ports or interfaces available on a networking equipment, such as a switch, router, or firewall, in relation to the physical size or form factor of the device? (2 marks)
10. A PC is to connect to a web server on another network. Which inter-VLAN approach will deliver the most bandwidth at Layer 3 while also serving as the PC's default gateway? (2 marks)

11. Cable transmission relates to the transfer of data, signals, or information using various types of cables as the medium for communication. Which cable type consists of a central conductor, an insulating layer, a metallic shield, and an outer insulating layer as shown below? (2 marks)



12. Optical network topology refers to the physical layout or structure of an optical network. Which topology has two endpoints connected directly through a single optical link? (2 marks)
13. A network administrator is addressing server connectivity issues. The administrator uses a tester to discover that the signals generated by the server NIC are distorted and unusable. Which layer of the OSI model is the error classified in? (2 marks)
14. Which form of communication is enabled by the two strands of fiber utilised for a single fiber optic connection? (2 marks)
15. Which Unshielded twisted pair (UTP) cable is used to connect a computer to a switch port? (2 marks)
16. What is the term used to describe an unwanted and unplanned event in electronic and electrical systems in which signals on one channel interfere with signals on another neighboring channel? (2 marks)
17. Which computer networking and systems administration concept is a decentralised network structure where individual computers are responsible for their own security, user authentication and resource sharing? (2 marks)
18. Which type of messages are typically created by multiple hardware and software components and routed to a central server for storage, analysis, and alerting? (2 marks)
19. What is the component of an IP address that identifies a specific device within a subnet? (2 marks)
20. Which standards organisation monitors the development of wireless LAN standards? (2 marks)

SECTION II (60 MARKS)

21. Create a word processing document named “Question 21” and use the word processor document to save your captured screenshot of your findings to questions (a) and (b).
- (a) Variable Length Subnet Masking (VLSM) is a technique used in IP addressing and subnetting to allocate different subnet mask lengths to different subnetworks within the same larger network.
- You have been given the IP address 192.168.5.0/24 and need to subnet it into multiple smaller subnetworks using VLSM to accommodate the following requirements:
- (i) Subnet A: 30 hosts (4 marks)
 - (ii) Subnet B: 15 hosts (4 marks)
 - (iii) Subnet C: 6 hosts (4 marks)
 - (iv) Subnet D: 2 hosts (4 marks)
- Calculate the subnet masks and valid IP address ranges for each subnet.
- (b) Highlight **FOUR** benefits of subnetting. (4 marks)

Save and upload Question 21.

(Total: 20 marks)

22. Create a word processing document named “Question 22” and use the word processor document to save your screenshot captured in your findings to questions (a) to (c).

Configure the topology below and answer the following questions.

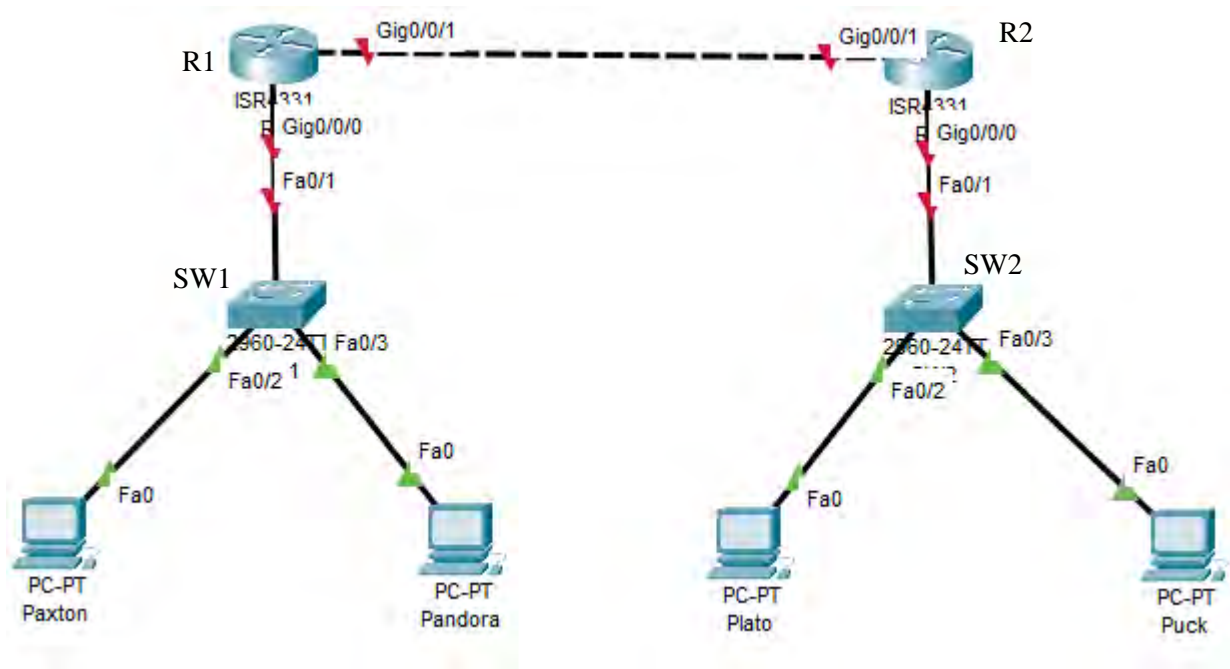

Device	Interface	IP Address	Subnet Mask	Default Gateway
R1	G0/0/0	192.168.0.9	255.255.255.248	N/A
	G0/0/1	192.168.0.1	255.255.255.252	N/A
R2	G0/0/0	192.168.0.17	255.255.255.248	N/A
	G0/0/1	192.168.0.2	255.255.255.252	N/A
SW1	VLAN 1	192.168.0.10	255.255.255.248	192.168.0.1
SW2	VLAN 1	192.168.0.18	255.255.255.248	192.168.0.17
Paxton	NIC	192.168.0.11	255.255.255.248	192.168.0.1
Pandora	NIC	192.168.0.12	255.255.255.248	192.168.0.1
Plato	NIC	192.168.0.19	255.255.255.248	192.168.0.17
Puck	NIC	192.168.0.20	255.255.255.248	192.168.0.17

Required:

- (a) Configure IP address for all intermediary and end devices and test connectivity as follows:
- (i) Paxton to R1. (2 marks)
 - (ii) Pandora to SW1. (2 marks)
 - (iii) Plato to R2. (2 marks)
 - (iv) Puck to SW2. (2 marks)

- (b) A static route is a manually configured route in a computer network that specifies how data packets should be forwarded to a specific destination. Configure R1 and R2 to display their respective remote networks.
- (i) Configure R1. (4 marks)
- (ii) Configure R2. (4 marks)
- (c) Highlight **FOUR** advantages of Static Routing. (4 marks)

Save and upload Question 22.

(Total: 20 marks)

23. Create a word processing document named “Question 23” and use the word processor document to save your captured screenshot of your findings to questions (a) to (d).

Use the topology in Question 22 and the addressing table below to answer the following questions.

Device	Interface	IPv6 Address	Prefix	Default Gateway
R1	G0/0/0	2001:DB8:ACAD:8::9	/64	N/A
	G0/0/1	2001:DB8:ACAD:0::1	/64	N/A
R2	G0/0/0	2001:DB8:ACAD:16::17	/64	N/A
	G0/0/1	2001:DB8:ACAD:0::2	/64	N/A
SW1	VLAN 1	2001:DB8:ACAD:8::10	/64	2001:DB8:ACAD:8::9
SW2	VLAN 1	2001:DB8:ACAD:16::18	/64	2001:DB8:ACAD:16::17
Paxton	NIC	2001:DB8:ACAD:8::11	/64	2001:DB8:ACAD:8::9
Pandora	NIC	2001:DB8:ACAD:8::12	/64	2001:DB8:ACAD:8::9
Plato	NIC	2001:DB8:ACAD:16::19	/64	2001:DB8:ACAD:16::17
Puck	NIC	2001:DB8:ACAD:16::20	/64	2001:DB8:ACAD:16::17

Required:

- (a) Configure the IP address configuration on the routers and end devices to be dual stack and test connectivity as follows:
- (i) Paxton to Pandora computer. (2 marks)
- (ii) Plato to Puck computer. (2 marks)
- (b) Display the configuration of IPv6 address on the following switches:
- (i) SW1 (4 marks)
- (ii) SW2 (4 marks)
- (c) Display configuration of remote access using SSH from R2 using appropriate username and password. (6 marks)
- (d) Use Puck PC to access R2 remotely using SSH. (2 marks)

Save and upload Question 23.

(Total: 20 marks)



CISSE INTERMEDIATE LEVEL
NETWORKING AND DATA COMMUNICATION

WEDNESDAY: 23 August 2023. Afternoon Paper.

Time Allowed: 3 hours.

Answer ALL questions. This paper has two sections. SECTION I has twenty (20) short response questions carrying forty (40) marks. SECTION II has three (3) practical questions carrying sixty (60) marks. Marks allocated to each question are shown at the end of the question.

Required Resources:

- A computer
- Internet connection
- Network simulator such as packet tracer or GNS3

SECTION I (40 MARKS)

1. The conceptual framework that standardises the functions of a communication system or network into seven different layers is known as _____ . (2 marks)
2. What is the name given to a network security technique that divides a network into smaller, distinct sub-networks that enable network teams to compartmentalise the sub-networks and delivers unique security controls and services to each sub-network? (2 marks)
3. A routed protocol provides appropriate addressing information in its internet layer to allow a packet to be forwarded from one network to another. What is the name of the address that is used when it is required to reach all devices on the IPv4 network? (2 marks)
4. A newly acquired computer was to be assigned to the CEO's office, IPv4 address 172.30.10.33 and subnet mask of 255.255.255. 224. What is the network address of the newly acquired computer? (2 marks)
5. What is the name given to the measure of usable data transferred over a given period of time? (2 marks)
6. Network media entails communication channels used to interconnect nodes on a computer network. Which media uses patterns of microwaves to represent bits? (2 marks)
7. Data is transmitted on copper cables as electrical pulses. Which type of copper cable media counters Electromagnetic Interference (EMI) and Radio Frequency Interference (RFI) by using shielding techniques and special connectors? (2 marks)
8. A type of network topology where each node in the network is connected to every other node directly is known as _____ . (2 marks)
9. A newly established Small Medium Enterprise (SME) would wish to extend its capabilities of IT without requiring investment in new infrastructure, training new personnel, or licensing new software and offers delivery of services on-demand to any device that is anywhere in the world without compromising security or function. Which technology can they embrace to accomplish the objective based on the scenario given? (2 marks)

10. What is the name given to a protocol used to distribute and synchronise identifying information about VLANs configured throughout a switched network? (2 marks)
11. The Internet Assigned Numbers Authority (IANA) is the standards organisation responsible for assigning various addressing standards, including the 16-bit port numbers. What is the name given to port numbers reserved for common or popular services and applications such as web browsers, email clients, and remote access clients? (2 marks)
12. A device that is located at the endpoint of a network segment and is responsible for impedance matching and signal reflection prevention is known as? (2 marks)
13. Port speed refers to the maximum speed at which data can be transferred. Which port speed will be auto negotiated between a host with a 1Gbps NIC connecting to a switch with a 100 Mbps port? (2 marks)
14. Which is the layer three (3) device that can be used to separate broadcast domains in a network? (2 marks)
15. A network protocol that allows a user to establish a remote terminal session with a remote device or computer over a network providing a text-based interface through which a user can remotely access and interact with the command-line interface of the remote system is known as _____ . (2 marks)
16. What is the general term given to the structure or pattern in which each and every node in the network is connected? (2 marks)
17. The network diagram below uses transmitters to cover a medium-sized network, usually up to 300 feet. Identify the type of network shown.

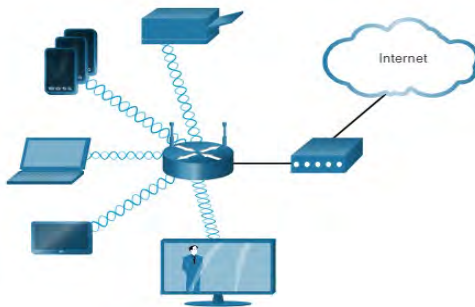

18. What is the name given to a protocol that can control multiple Wi-Fi wireless access points at once? (2 marks)
19. Routers learn about _____ through Static routes or Dynamic routing protocols. (2 marks)
20. A unit of data that is transmitted over a network which is also the basic building block of communication between devices on a network is known as _____ . (2 marks)

SECTION II (60 MARKS)

QUESTION 21

Consider the topology diagram below that use 192.168.100.0/24 to create subnets in order to meet the requirement of the number of hosts in the network.

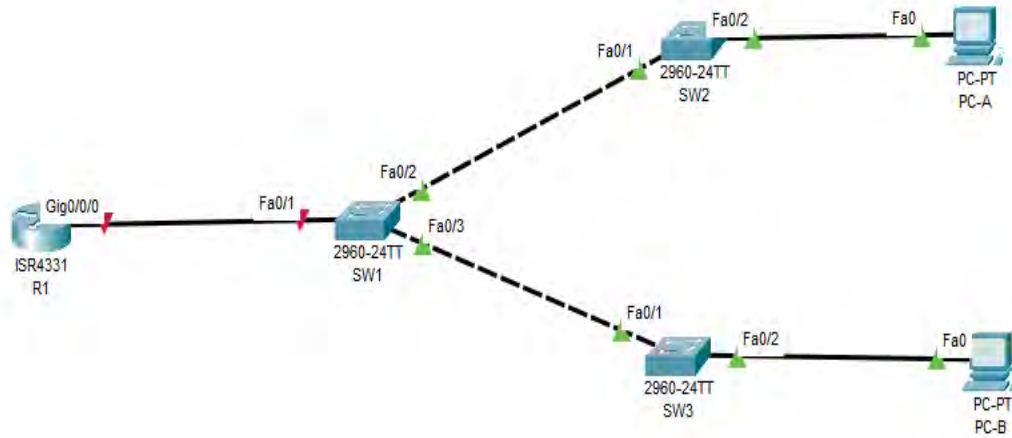

Required:

Compute the following:

- The subnet mask for 60 Hosts. (6 marks)
- The 1st available address to be assigned in R1's G0/0/0 interface (Gateway)? (2 marks)
- Second available address to be assigned on SW1? (2 marks)
- The 5th available address to be assigned on SW2? (2 marks)
- The 10th available address to be assigned on SW3? (2 marks)
- The second to last available address to be assigned to PC-A? (2 marks)
- Second to last available address to be assigned to PC-B? (2 marks)
- The broadcast address? (2 marks)

(Total: 20 Marks)

QUESTION 22

Create a word processing document named "Question 22" and use it to save screenshots showing how you have performed the task in questions (a) to (c) below.

Required:

- Use Packet tracer or GNS3 simulators to configure the topology given in Question 21. (12 marks)
- Using appropriate command utility, trace the path from PC-A to PC-B. (4 marks)
- Using appropriate command utility, configure default gateway on SW2. (4 marks)

Save "Question 22" document and upload.

(Total: 20 Marks)

QUESTION 23

Create a word processing document named “Question 23” and use it to save screenshots showing how you have performed the task in questions (a) to (c) below:

Required:

Use the topology in Question 21 to answer the following questions.

- (a) Configure the port security feature on SW2 and SW3 on the respective ports connected to end devices. (12 marks)
- (b) Configure PORTFAST and BPDU GUARD on the end device connected to SW2. (6 marks)
- (c) Test connectivity between PC-B and SW1. (2 marks)

Save “Question 23” document and upload. **(Total: 20 marks)**

.....

Chopi.co.ke



CISSE INTERMEDIATE LEVEL
NETWORKING AND DATA COMMUNICATION

WEDNESDAY: 26 April 2023. Afternoon Paper.

Time Allowed: 3 hours.

Answer ALL questions. This paper has two sections. SECTION I has twenty (20) short response questions carrying forty (40) marks. SECTION II has three (3) practical questions carrying sixty (60) marks. Marks allocated to each question are shown at the end of the question.

Required Resources:

- A computer
- Internet connection
- Simulator such as packet tracer or GNS3

SECTION I (40 MARKS)

1. Which of the following is a type of network topology where various nodes of the network are connected together with a single switch? (2 marks)
2. A computer network that connects computers in a limited geographical area is referred to as? (2 marks)
3. _____ is the data transmission mode that uses two channels to transmit data in a bidirectional manner. (2 marks)
4. The devices that form the interface between users and the underlying communication network are referred to as? (2 marks)
5. The tool that can be used to terminate a twisted pair cable with an RJ45 connector is referred to as? (2 marks)
6. The OSI Model layer that is responsible for transmission and reception of the unstructured raw data over the network is referred to as? (2 marks)
7. The application layer, the transport layer, the internet layer and the network access layer are collectively referred to as? (2 marks)
8. The IP addressing activity that provides the flexibility of borrowing bits of host part of the IP address and using them as network in the subnet is referred to as? (2 marks)
9. The IP address 172.16.5.1 can be classified as belonging to which IPv4 class? (2 marks)
10. Which type of routing protocol is used when an administrator manually assigns the path from source to the destination network and offers more security to the network? (2 marks)
11. Using the diagram below as the reference, which addressing scheme reduces the number of addresses per subnet to a size appropriate for the networks that require fewer subnets? (2 marks)

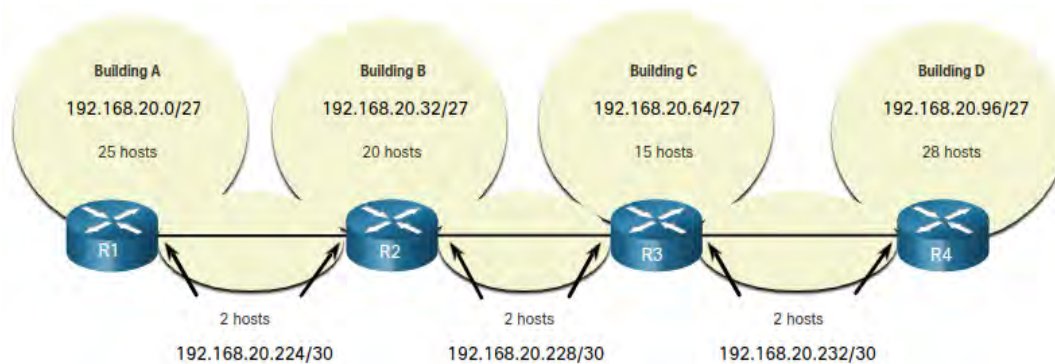

12. The network protocol that assigns a variety of related networking parameters including subnet mask, domain name server and default gateway address is referred to as? (2 marks)
13. The type of network that provides wireless network coverage in places with difficult cabling such as subways and roadways is referred as? (2 marks)
14. Give the name of the normal VLAN range that can be created, edited and deleted. (2 marks)
15. Which is the network troubleshooting tool or command that is used to test the network activity between the router and the Google DNS servers? (2 marks)
16. _____ is the command that is executed in global configuration and configures an NTP server as a preferred server when multiple servers are configured. (2 marks)
17. Which is the logical interface internal to the router and is automatically placed in an UP state, as long as the layer 3 device is functioning? (2 marks)
18. In computer network troubleshooting, which tool is used to validate throughput and packet loss from end to end? (2 marks)
19. The type of WAN network that is highly vulnerable to cyber-attacks is referred to as? (2 marks)
20. The type of network domain that allows traffic to flow forward and backward is referred to as? (2 marks)

SECTION II (60 MARKS)

21. Create a word processing document named "Address Type" and use the word processor document to save your answers to questions (a) and (b)

- (a) Analyse and name the address type of the following IPv6 address. (10 marks)

IPv6 Address	Address type
2001:ACAD:CAFE:800:FE55:6789:B210	
::1	
FC00:44:A:2::CD4:23E4:76FA	
FE80::3201:CC01:65B1	
FF00::	

- (b) Internet Protocol version 6 (IPv6) provides an identification and location system for computers on networks and routes traffic across the Internet. Using the rules of abbreviation, either compress or decompress the following addresses?
 - (i) 2000:CDDC:0600:0001:0000:04AB:44DE:08A2 (2 marks)
 - (ii) FE80::9068:B3D7:3DAB:84B8 (2 marks)

- (iii) FF00 (2 marks)
- (iv) 2001:0040:0010: ACAD: 0000:330E: 10C2:32BF (2 marks)
- (v) FE80:0000:0000:0000:8D4F:4F4D:3237:95E2 (2 marks)

Save and upload “Address Type” document.

(Total:20 marks)

22. Create a word processing document named “Topology” use the word processor document to save your answers to questions (a) to (c)

Using the appropriate simulator, configure the topology as shown below and capture screenshot of your configuration in word document.

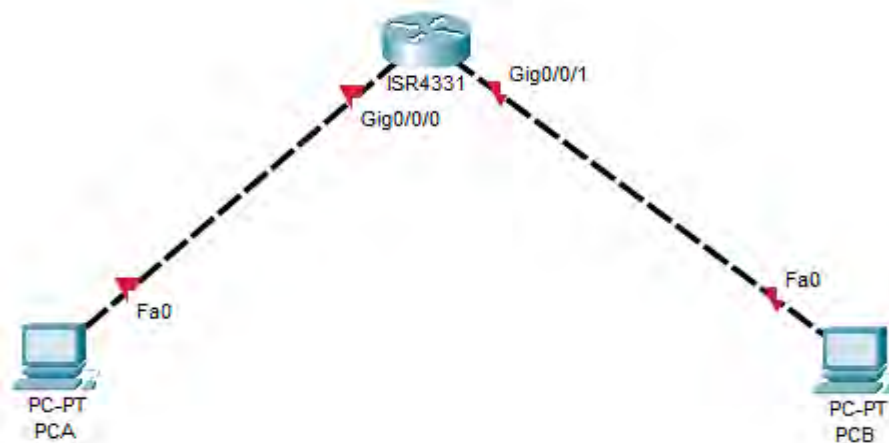

www.chopi.co.ke

Device	Interface	IPv6 Address	Prefix Length	Default gateway
R1	G0/0/0	2001:DB8:ABCD:100::1	64	N/A
	G0/0/1	2001:DB8:ABCD:200::1	64	N/A
PC-A	NIC	2001:DB8:ABCD:100::2	64	FE80::1
PC-B	NIC	2001:DB8:ABCD:200::2	64	FE80::1

Required:

- (a) Configure the routed protocol on the intermediary device for the two interfaces. (4 marks)
- (b) Using appropriate command utility, trace the path from PC-A to PC-B (4 marks)
- (c) Using appropriate command utility, display the link local address for the following:
 - (i) G0/0/0 Interface (3 marks)
 - (ii) G0/0/1 interface (3 marks)
 - (iii) PCA (3 marks)
 - (iv) PCB (3 marks)

Save “Topology” document and upload.

(Total: 20 marks)

23. Create a word processing document named “Network Configuration”. Use the word processor document to save your answers to questions (a) to (d)

Using the appropriate simulator, configure the topology as shown below and capture screenshot of your configuration in word document?

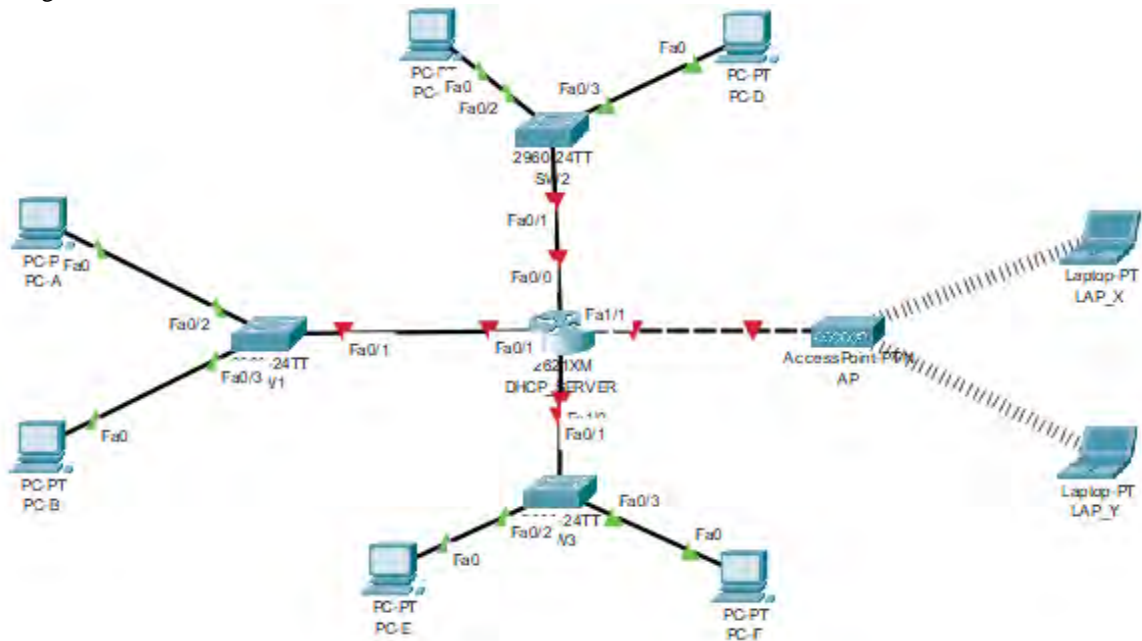

Device	Interface	IPv4 Network Address
Router	F0/0	192.168.10.0/27
	F0/1	192.168.10.32/27
	F0/1	192.168.10.64/27
	F1/1	192.168.10.96/27

Required:

- (a) Configure Dynamic host control protocol (DHCP) on the Router to make it a DHCP server for the ethernet networks (12 marks)
- (b) Enable Automatic IP address Configuration on PC-A and PC-B (4 marks)
- (c) Test connectivity between PC-A and Laptop X. (2 marks)
- (d) Use appropriate command utility in the CLI to display the routing table. (2 marks)

Save and upload “Network Configuration” document.

(Total:20 marks)

.....



CISSE INTERMEDIATE LEVEL

NETWORKING AND DATA COMMUNICATION

WEDNESDAY: 7 December 2022. Afternoon Paper.

Time Allowed: 3 hours.

Answer ALL questions. This paper has two sections. SECTION I has twenty (20) short response questions of forty (40) marks. SECTION II has three (3) practical questions of sixty (60) marks. Marks allocated to each question are shown at the end of the question.

Required Resources:

- A computer
- Internet connection
- Simulator such as packet tracer or GNS3

SECTION I

1. Protocols such as Open Shortest Path First (OSPF) and Enhanced interior Gateway Routing Protocol (EIGRP) which ensures routers exchange route information, compare path information and select best path to destination network are known as? (2 marks)
2. What is the name of the service discovery protocol that translates human readable domain name to machine readable IP address? (2 marks)
3. Fiber optic cable transmits data as pulses of light through flexible, optically pure fibers of glass or plastic. Which of the type of fiber-optic cable can help data travel approximately 500 meters? (2 marks)
4. A network administrator is designing a new network infrastructure with the objective of ensuring end user mobility when connecting to the network. Which type of connection would be recommended? (2 marks)
5. Transport Layer is the fourth layer from the top in Open Systems Interconnection (OSI) Model which provides communication services to the application processes that was running on different hosts. Which transport layer protocol ensures reliable same-order delivery? (2 marks)
6. The Internet Assigned Numbers Authority (IANA) is the standards organization responsible for assigning various addressing standards using 16-bit port number that identifies the source and destination. Which port group includes port numbers for FTP, HTTP, and TFTP applications? (2 marks)
7. What is the name given to a protocol that allows users to share whole files with other users?
8. What is the name of the protocol that allows a client to download data from or upload data to the server? (2 marks)
9. The prefix-length is a decimal value indicating the number of leftmost contiguous bits of the address. What is the prefix length notation for the subnet mask 255.255.255.248?
10. Which component of an IP address identifies computer on a network? (2 marks)
11. The compressed representation of IPv6 address 2001: CAFE:0DB8:0001:0000:0000:0000:0010 is? (2 marks)

12. Which command utility can be used to test internal configuration of an IPv6 host? (2 marks)
13. Mr. Lidibwe a newly hired technician is troubleshooting a network where it is suspected that a defective node in the network path is causing packets to be dropped. The technician has only IP address of the end point device with no other details provided. Which command utility can be used by the technician to identify the faulty node? (2 marks)
14. The message sent by a host to check the uniqueness of an IPv6 address before using that address is referred to as? (2 marks)
15. Give the name of a TCP mechanism used to enhance performance by allowing a device to continuously send a steady stream of segments as long as the device is also receiving necessary acknowledgements. (2 marks)
16. What is the name given to small, wireless transmitters that use low-energy Bluetooth technology to send signals to other smart devices nearby? (2 marks)
17. Communications technology refers to all equipment and programs that are used to process and communicate information. Which type of telecommunication technology is used to provide Internet access to vessels at sea? (2 marks)
18. Which Intermediary device connects multiple IP packets and determines the best path to send packets? (2 marks)
19. A feature that allows routers to select the best path to use whenever there are two or more different routes to the same destination from two different routing protocols is referred to as _____ . (2 marks)
20. The following IP Address 192.168.10.63/27 can be categorised as which kind of address? (2 marks)

SECTION II

21. Variable Length Subnet Mask (VLSM) was designed to avoid wasting IP addresses. With VLSM, a network is subnetted and then re-subnetted. This process can be repeated multiple times to create subnets of various sizes based on the number of hosts required in each subnet. Effective use of VLSM requires address planning.

Use the diagram below to answer the questions that follow:

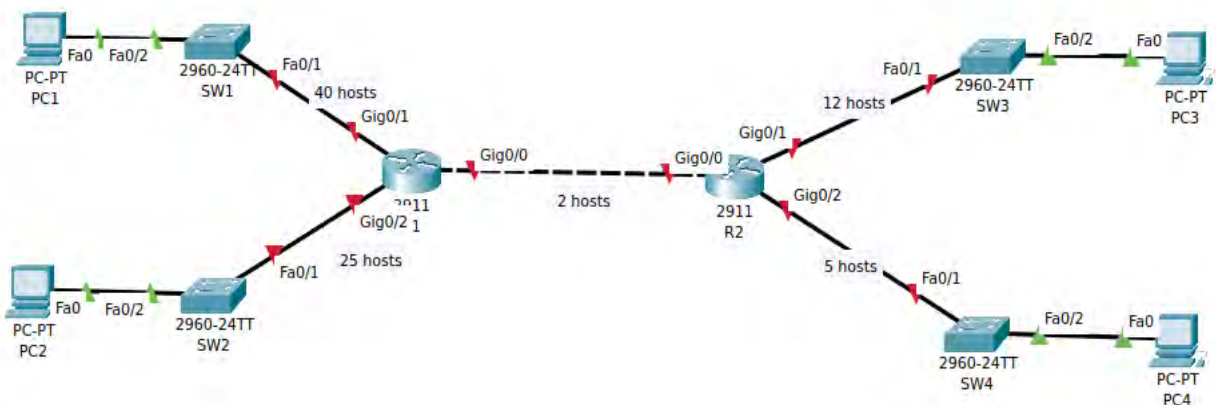

IP ADDRESS: 192.168.10.0/24

- (a)
 - (i) How many IP addresses are required in the largest subnet? (2 marks)
 - (ii) What subnet mask can support that many host addresses? (2 marks)
- (b)
 - (i) How many IP addresses are required in the second largest subnet? (2 marks)
 - (ii) What subnet mask can support that many host addresses? (2 marks)
- (c)
 - (i) How many IP addresses are required in the third largest subnet? (2 marks)
 - (ii) What subnet mask can support that many host addresses? (2 marks)

- (d) (i) How many IP addresses are required in the fourth largest subnet? (2 marks)
 - (ii) What subnet mask can support that many host addresses? (2 marks)
 - (e) (i) How many IP addresses are required in the fifth largest subnet? (2 marks)
 - (ii) What subnet mask can support that many host addresses? (2 marks)
- (Total: 20 marks)**

22. Using a network simulator and the details you obtained in Question 21, answer the following questions:

- (a) Use the first network address of the largest subnet to configure your network based on the topology and capture a screenshot showing IP details configuration. (4 marks)
- (b) Use the first network address of the second largest subnet to configure your network based on the topology and capture a screenshot showing IP details configuration. (4 marks)
- (c) Use the first network address of the third largest subnet to configure your network based on the topology and capture a screenshot showing IP details configuration. (4 marks)
- (d) Use the first network address of the fourth largest subnet to configure your network based on the topology and capture a screenshot showing IP details configuration. (4marks)
- (e) Use the first network address of the fifth largest subnet to configure your network based on the topology and capture a screenshot showing IP details configuration. (4 marks)

Upload Question 22 document.

(Total: 20 marks)

23. Create a word processing document named “Question 23” and use the word processor document to save your answers to questions (a) to (d).

Using appropriate simulator, setup the topology as shown below

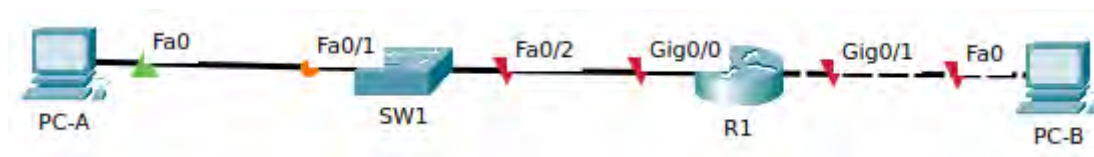

Device	Interface	IPv6 Address	Prefix Length	Default gateway
R1	G0/0	2001:CAFE:ABCD:1::1	64	N/A
	G0/1	2001:CAFE:ABCD:2::1	64	N/A
SW1	VLAN 1	2001:CAFE:ABCD:1::2	64	N/A
PC-A	NIC	2001:CAFE:ABCD:1::3	64	FE80::1
PC-B	NIC	2001:CAFE:ABCD:2::1	64	FE80::1

Required:

- (a) Configure the global unicast IPv6 address provided in the table to the intermediary and end user devices. Capture a screenshot of the output. (8 marks)
- (b) Using a command utility, test connectivity between PC-A and PC-B. (2marks)
- (c) Using PC-B, access R1 remotely using Secure Shell (SSH). (6 marks)
- (d) Disable unused switch ports on SW1. (4 marks)

Upload Question 23 document.

(Total: 20 marks)

.....



CISSE INTERMEDIATE LEVEL

NETWORKING AND DATA COMMUNICATION

WEDNESDAY: 3 August 2022. Afternoon paper.

Time Allowed: 3 hours.

This paper has two sections. SECTION I has twenty (20) questions of forty (40) marks. SECTION II has three (3) practical questions of sixty (60) marks. All questions are compulsory. Marks allocated to each question are shown at the end of the question.

SECTION I

1. What is the name of the media used to transmit data that is encoded as pulses of light? (2 marks)
2. An IPv6 _____ is an address that is assigned to a set of interfaces that typically belong to different nodes. (2 marks)
3. Which category of network devices performs the following functions?
 - Regenerate and transmit communication signals
 - Maintains information about what pathways exist through the network and internetwork
 - Notify other devices of errors and communication failures. (2 marks)
4. Which communication term is used to describe the piece of information sent between one sender and one receiver? (2 marks)
5. The term _____ is used to describe a piece of data at any layer of a networking model. (2 marks)
6. What is the name given the process of placing one message into another message format for transfer from source to destination? (2 marks)
7. Mr. Shawn a newly employed Network administrator is troubleshooting network connectivity issues on a server. He noticed signals generated by the server NIC using a tester were distorted. Which layer of the OSI reference model is associated with the error? (2 marks)
8. _____ refers to the amount of data that can flow from one place to another in a given amount of time (2 marks)
9. What is the measure of the transfer of bits across the media over a given time period? (2 marks)
10. Computer systems were created to understand binary addressing. Which IPv4 address format was created for ease of use by people ? (2 marks)
11. What is the name given to the data transmitted over the network and can flow in one direction at a time? (2 marks)
12. The data link layer of the Open System Interconnection Model (OSI) describes media access and physical addressing where the encoding of a MAC address on a Network Interface card is placed. Which layer of the OSI model is the Internet Protocol (IP) Address placed? (2 marks)

13. You have been tasked to develop a physical topology network for an upcoming cement industry that provides a high level of redundancy. Which physical topology interconnects multiple groups that are located on the separate layers to form a larger network? (2 marks)
14. An IPv4 address of 192.168.60.255 on 192.168.60.0/24 network is considered to be _____ address, which is statically mapped to ff-ff-ff-ff-ff-ff in the ARP table (2 marks)
15. Which message attributed to IPv6 is sent by a node to determine the link-layer address of a neighbor is still reachable via a cached link-layer address? (2 marks)
16. _____ allows a laptop or PC to use the Internet connection of a mobile device such as a cell phone, usually through a cellular data connection. (2 marks)
17. A WAP is a device that allows different types of wireless network cards connect without cables, hence wireless, to connect to LANs and access resources, including the Internet. Which feature of 802.11n wireless access points allows them to transmit data at faster speeds? (2 marks)
18. Internet access is the ability of individuals and organizations to connect to the Internet using computer terminals and other devices. Which type of telecommunication technology is used to provide Internet access to vessels at sea and airplanes in flight. (2 marks)
19. Which type of IPv6 address can only be used for communication on a single network and **NOT** other networks using routed protocol? (2 marks)
20. Which IPv4 subnet mask would be used if 2 host bits are available? (2 marks)

SECTION II

21. Create word processing document named Question 21 and use it to save solution to questions (i) to (iv) below in form of screenshots.

Network administrator's use /24 network address to subdivide a network using longer prefix lengths by borrowing bits from the fourth octet in order to assign network addresses to a smaller number of end devices.

Analyse the diagram below and answer the following questions:

Prefix Length	Subnet Mask	Subnet mask in binary	No. of subnets	No. of hosts
/25				
/26				
/27				
/28				
/29				
/30				

Required:

- (i) Compute the subnet mask for each prefix length. (4 marks)
- (ii) Compute the subnet mask in binary for each prefix length. (4 marks)
- (iii) State the Number of subnets for each prefix length. (6 marks)
- (iv) State the number of hosts for each prefix length. (6 marks)

Upload Question 21 document.

(Total: 20 marks)

22. Create a word-processing document named Question 22 use it to save solutions to question (i) to (vi) below in form of screenshots.

Required Resources

PC (Windows/Linux with internet access and Wireshark installed)

Data flows down the Open System Interconnection (OSI) layers when upper layer protocols communicate with each other and is encapsulated into layer 2 frame. Use Wireshark to examine Ethernet frames of the topology you are using. The topology is represented by the diagram below.

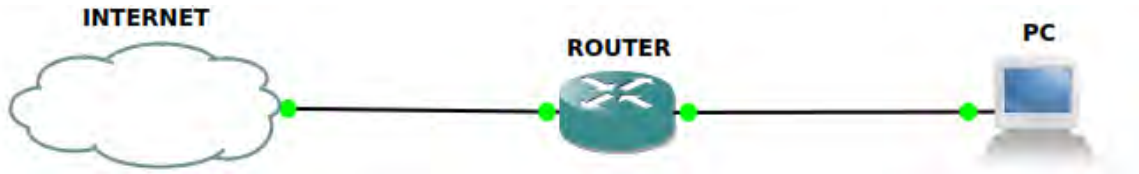

Required:

- (i) Examine and record the network configuration of your host PC (4 marks)
- (ii) Using Wireshark capture the following:
 - Frame details of the ARP Request (3 marks)
 - Frame details of the ARP Reply (3 marks)
- (iii) Identify and list the significance about the contents of the destination address field. (2 marks)
- (iv) Capture details showing the MAC address of the source in the first frame. (2 marks)
- (v) Capture details showing the MAC address of the destination in the first frame. (2 marks)
- (vi) Capture details showing the Vendor ID (OUI) of the Source NIC in the ARP reply. (4 marks)

Upload question 22 document.

(Total: 20 marks)

23. Create a word-processor document named Question 23 use it to save solutions to question (i) to (vi) below in form of screenshots.

Use a simulator to design the topology as shown below:

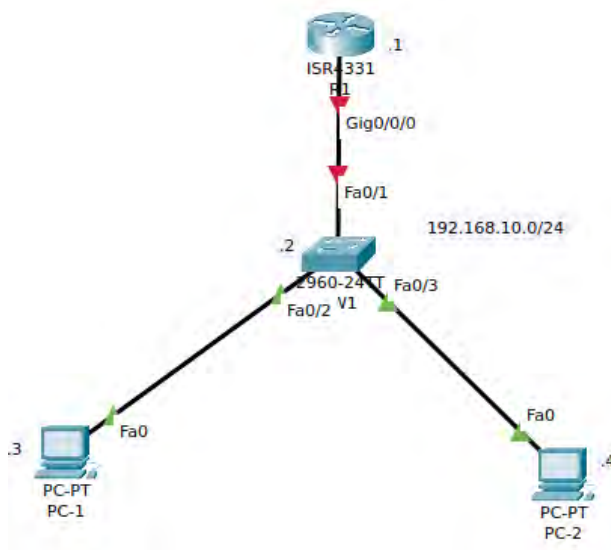

Required Resources

Packet Tracer/GNS3 simulator

Required:

- (i) Configure appropriate names to the Router (3 marks)
- (ii) Configure a warning banner (3 marks)
- (iii) Configure appropriate interface descriptions (3 marks)
- (iv) Configure unicast IPv4 addresses as shown in the topology (4 marks)
- (v) Disable DNS lookup (3 marks)
- (vi) Configure encrypted privileged execution password (4 marks)

Upload question 23 document.

(Total: 20 marks)

.....

www.chopi.co.ke